

## Ball-end thrust screws without head, with full ball, with thread lock

### Item description/product images

#### KIPPlack



#### Description

##### Version:

Screw black.  
Ball hardened, bright.

##### Note:

Ball-end thrust screws with full ball are used when a clean, polished contact surface is required.

##### Drawing reference:

Style A: steel ball  
Style D: POM ball

L2 = approx. 2x pitch

### Drawings

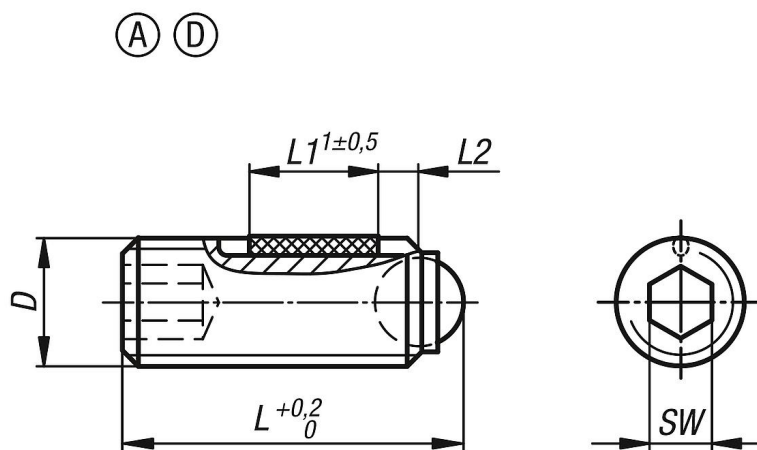

### Ball-end thrust screws without head, steel, with full ball, with thread lock

Item No.	style	Component material	D	L	L1	Ball-Ø	SW	Load rating max. kN (static load only)
K0666.1046	A	ball-bearing steel	M4	6	2,5	2,5	2	3,5
K0666.10410	A	ball-bearing steel	M4	10	3,5	2,5	2	3,5
K0666.10416	A	ball-bearing steel	M4	16	5	2,5	2	3,5
K0666.1058	A	ball-bearing steel	M5	8	3,5	3	2,5	4,5
K0666.10512	A	ball-bearing steel	M5	12	5	3	2,5	4,5
K0666.10520	A	ball-bearing steel	M5	20	6	3	2,5	4,5
K0666.10610	A	ball-bearing steel	M6	10,8	3,5	4	3	9
K0666.10616	A	ball-bearing steel	M6	16,8	7	4	3	9
K0666.10620	A	ball-bearing steel	M6	20,8	7	4	3	9
K0666.10625	A	ball-bearing steel	M6	25,8	7	4	3	9
K0666.10650	A	ball-bearing steel	M6	50,8	7	4	3	9
K0666.10660	A	ball-bearing steel	M6	60,8	7	4	3	9
K0666.10810	A	ball-bearing steel	M8	11,2	3,5	5,5	4	10
K0666.10812	A	ball-bearing steel	M8	13,2	5	5,5	4	10
K0666.10820	A	ball-bearing steel	M8	21,2	8	5,5	4	15
K0666.10825	A	ball-bearing steel	M8	26,2	8	5,5	4	15

## Ball-end thrust screws without head, with full ball, with thread lock

Item No.	style	Component material	D	L	L1	Ball-Ø	SW	Load rating max. kN (static load only)
K0666.10830	A	ball-bearing steel	M8	31,2	8	5,5	4	15
K0666.10850	A	ball-bearing steel	M8	51,2	8	5,5	4	15
K0666.10860	A	ball-bearing steel	M8	61,2	8	5,5	4	15
K0666.10880	A	ball-bearing steel	M8	81,2	8	5,5	4	15
K0666.11012	A	ball-bearing steel	M10	13,7	5	7	5	20
K0666.11016	A	ball-bearing steel	M10	17,7	9	7	5	20
K0666.11020	A	ball-bearing steel	M10	21,7	9	7	5	20
K0666.11025	A	ball-bearing steel	M10	26,7	9	7	5	20
K0666.11035	A	ball-bearing steel	M10	36,7	9	7	5	20
K0666.11216	A	ball-bearing steel	M12	18	8	8,5	6	30
K0666.11220	A	ball-bearing steel	M12	22	10	8,5	6	30
K0666.11230	A	ball-bearing steel	M12	32	10	8,5	6	30
K0666.11240	A	ball-bearing steel	M12	42	10	8,5	6	30
K0666.11620	A	ball-bearing steel	M16	23,3	10	12	8	60
K0666.11625	A	ball-bearing steel	M16	28,3	14	12	8	60
K0666.11635	A	ball-bearing steel	M16	38,3	14	12	8	60
K0666.11650	A	ball-bearing steel	M16	53,3	14	12	8	60
K0666.3046	D	polyacetal	M4	6	2,5	2,5	2	0,3
K0666.30410	D	polyacetal	M4	10	3,5	2,5	2	0,3
K0666.30416	D	polyacetal	M4	16	5	2,5	2	0,3
K0666.3058	D	polyacetal	M5	8	3,5	3	2,5	0,5
K0666.30512	D	polyacetal	M5	12	5	3	2,5	0,5
K0666.30520	D	polyacetal	M5	20	6	3	2,5	0,5
K0666.30610	D	polyacetal	M6	10,8	3,5	4	3	0,9
K0666.30616	D	polyacetal	M6	16,8	7	4	3	0,9
K0666.30620	D	polyacetal	M6	20,8	7	4	3	0,9
K0666.30625	D	polyacetal	M6	25,8	7	4	3	0,9
K0666.30810	D	polyacetal	M8	11,2	3,5	5,5	4	1,5
K0666.30812	D	polyacetal	M8	13,2	5	5,5	4	1,5
K0666.30820	D	polyacetal	M8	21,2	8	5,5	4	1,5
K0666.30825	D	polyacetal	M8	26,2	8	5,5	4	1,5
K0666.30830	D	polyacetal	M8	31,2	8	5,5	4	1,5
K0666.31012	D	polyacetal	M10	13,7	5	7	5	2
K0666.31016	D	polyacetal	M10	17,7	9	7	5	2
K0666.31020	D	polyacetal	M10	21,7	9	7	5	2
K0666.31025	D	polyacetal	M10	26,7	9	7	5	2
K0666.31035	D	polyacetal	M10	36,7	9	7	5	2
K0666.31216	D	polyacetal	M12	18	8	8,5	6	3
K0666.31220	D	polyacetal	M12	22	10	8,5	6	3
K0666.31230	D	polyacetal	M12	32	10	8,5	6	3
K0666.31240	D	polyacetal	M12	42	10	8,5	6	3