

Threaded inserts self-tapping with cutting slot

Item description/product images



Description

Material:

Steel or 1.4305 (AISI 303 equivalent) stainless steel

Version:

Steel case hardened, electro zinc-plated.
Stainless steel bright.

Note:

Self-tapping threaded inserts for making high-strength, wear-free, vibration resistant screw connections in materials with low shear strength such as aluminum and aluminum alloys, brass, bronze, cast iron, duro and thermoplastics.

The threaded inserts are tapered at the bottom and have a cutting slot. By screwing in they cut their own threads inside a receiver hole. This guarantees a completely secure and firm anchoring in the host material.

Internal thread D1 acc. to ISO 6H.

The threaded inserts with cutting slot spring slightly inwards in the slot region in some materials. This results in a screw locking effect. If this is not desired, we recommend the threaded inserts with a cutting bore.

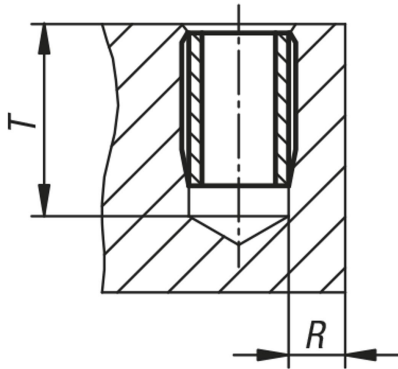

Drawings

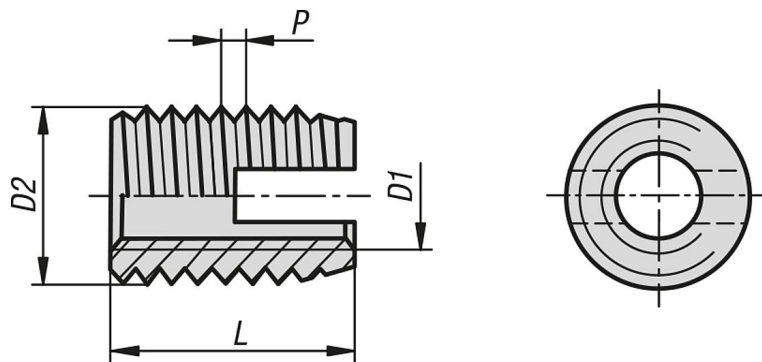

Item No.	Main material	D1 internal thread	D2	L length	P	T min.	R min. light metal	R min. cast iron	R min. plastics	Order No. Hand ass. tool	Order No. M/C ass. tool
K0978.03	steel	M3	5	6	0,5	8	1	1,5	1,25	K0978.803	K0978.903
K0978.04	steel	M4	6,5	8	0,75	10	1,3	1,95	1,6	K0978.804	K0978.904
K0978.05	steel	M5	8	10	1	13	1,6	2,4	2	K0978.805	K0978.905
K0978.06	steel	M6	10	14	1,5	17	2	3	2,5	K0978.806	K0978.906
K0978.08	steel	M8	12	15	1,5	18	2,4	3,6	3	K0978.808	K0978.908
K0978.10	steel	M10	14	18	1,5	22	2,8	4,2	3,5	K0978.810	K0978.910
K0978.12	steel	M12	16	22	1,5	26	3,2	4,8	4	K0978.812	K0978.912
K0978.16	steel	M16	20	22	1,5	27	4	6	5	-	K0978.916
K0978.103	stainless steel	M3	5	6	0,5	8	1	1,5	1,25	K0978.803	K0978.903
K0978.104	stainless steel	M4	6,5	8	0,75	10	1,3	1,95	1,6	K0978.804	K0978.904
K0978.105	stainless steel	M5	8	10	1	13	1,6	2,4	2	K0978.805	K0978.905
K0978.106	stainless steel	M6	10	14	1,5	17	2	3	2,5	K0978.806	K0978.906
K0978.108	stainless steel	M8	12	15	1,5	18	2,4	3,6	3	K0978.808	K0978.908

Threaded inserts self-tapping with cutting slot

Item No.	Main material	D1 internal thread	D2	L length	P	T min.	R min. light metal	R min. cast iron	R min. plastics	Order No. Hand ass. tool	Order No. M/C ass. tool
K0978.110	stainless steel	M10	14	18	1,5	22	2,8	4,2	3,5	K0978.810	K0978.910
K0978.112	stainless steel	M12	16	22	1,5	26	3,2	4,8	4	K0978.812	K0978.912
K0978.116	stainless steel	M16	20	22	1,5	27	4	6	5	-	K0978.916