

Weld-on D-rings

Item description/product images



Description

Material:

Eye 1.6541 steel.

Welding block, S355JR steel.

Version:

D-ring forged, high tensile tempered, red plastic coated.

Welding block forged, high tensile tempered, bright.

Note:

Weld-on D-rings enable quick installation.

They offer a compact design and can be loaded from all sides, with 4x safety factor against breakage.

The welding block is forged from easy to weld S355JR (St 52-3). The small knobs serve as spacers for the air gap required for fillet welding (ca. 3 mm).

The load data given in the table is clearly marked on the welding block, they apply to worst scenario cases for the lifting type shown.

Welding must be carried out by a proficient welder certified to EN 287-1.

Weld-on D-rings

Drawings

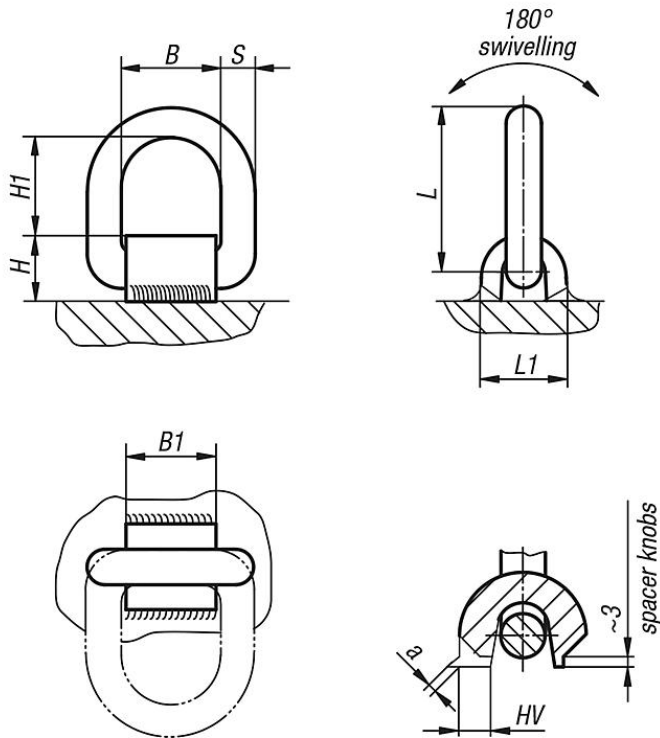

Maximum lifting weight "G" in kg for different sling types

Sling configuration																
	G	G	G	G	G	G	G	G	G	G	G	G	G	G	G	G
No. of slings	1	2	1	2	2	2	3 - 4	3 - 4								
Sling angle \sphericalangle	0°	0°	90°	90°	0°-45°	45°-60°	0°-45°	45°-60°								
K0773.1***	1600	3200	1120	2240	1500	1120	2360	1600								
K0773.2***	3000	6000	2000	4000	2800	2000	4000	3000								
K0773.3***	4750	9500	3150	6300	4250	3150	6300	4750								
K0773.5***	8000	16000	5300	10600	7100	5300	11200	8000								

Weld-on D-rings

Order No.	Version	B	B1	H	H1	L	L1	S	Weld seam	Permissible load kg
K0773.1000	without spring strip	40	38	32	40	73	38	13	HV 5 + a3	1120
K0773.2000	without spring strip	41	38	32	45	81	40	13	HV 5 + a3	2000
K0773.3000	without spring strip	45	43	38	45	87	42	17	HV 8 + a3	3150
K0773.5000	without spring strip	55	50	48	57	108	60	22	HV 12 + a4	5300
K0773.1001	with spring strip	40	38	32	40	73	38	13	HV 5 + a3	1120
K0773.2001	with spring strip	41	38	32	45	81	40	13	HV 5 + a3	2000
K0773.3001	with spring strip	45	43	38	45	87	42	17	HV 8 + a3	3150
K0773.5001	with spring strip	55	50	48	57	108	60	22	HV 12 + a4	5300

