

Support arm double

Item description/product images

METRIC
Parts

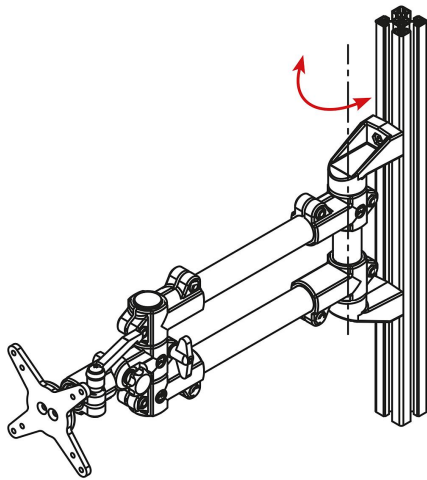

Description

Material:

High-strength material mix of thermoplastic/aluminum.

Version:

Black/bright.

Note:

We offer three different basic brackets for industrial monitors and touch panels:

Compact:

space-saving, with a swivel range of 60°. For loads up to 10 kg (static). With universal mounting plate. The basic bracket is suitable for mounting on tubes size Ø30 mm or 30x30 mm. By using the optional reducer body 29040 they can also be mounted on other sized tubes (Ø20 and Ø25 mm or 20x20 and 25x25 mm).

With rotary flange:

vibration-resistant, lockable monitor bracket with an angle adjustment of 90° in 15° increments. For monitors / control units up to 25 kg (static). With universal mounting plate. The basic bracket is suitable for mounting on tubes size Ø30 mm. By using the optional reducer body 29042 they can also be mounted on other sized tubes (Ø20 and Ø25 mm or 20x20 mm).

With ball joint:

enables a swivel range of 60°. For loads up to 10 kg (static). With universal mounting plate. The basic bracket is suitable for mounting on tubes size Ø30 mm. By using the optional reducer body 29042 they can also be mounted on other sized tubes (Ø20 and Ø25 mm or 20x20 mm).

Optional wall bracket, profile bracket, single/double support arms, tablet holder, keyboard tray or a VESA 50/75 or 75/100 connecting plate are available to offer various connections.

Drawings

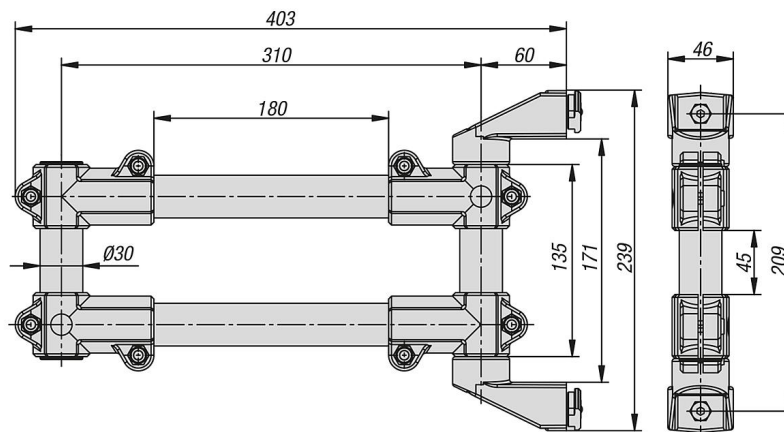

Support arm double

Order No.	Image	Version 1
K1510.3012		support arm double
