

Ratchet elements, style F with external toothing

Item description/product images

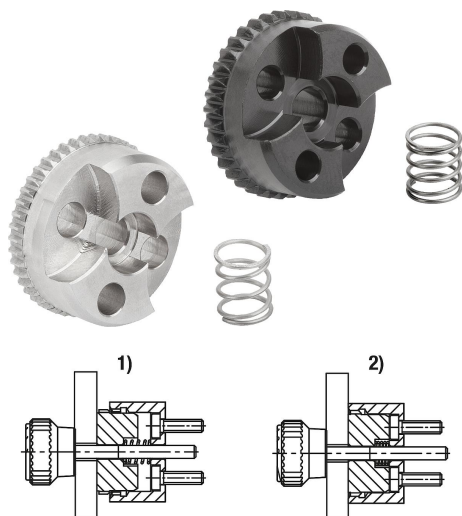

Description

Product description:

Ratchet elements are used to connect two components together in any angular position with a positive fit. The ratchet elements with internal toothing (styles A–D) can be combined with the ratchet elements with external toothing (styles E–H) in any way depending on the application and installation possibilities. The springs mean that a new angular position can be quickly implemented.

Material:

Ratchet element steel 1.0718 or stainless steel 1.4305 (AISI 303 equivalent).
Spring stainless steel 1.4310 (AISI 301 equivalent).
Cap screws steel or stainless steel A 2.

Version:

Ratchet element black oxidized steel or bright stainless steel.
Spring bright.
Cap screw blackened steel grade 8.8 or bright A2-70 stainless steel.

Order information:

2 cap screws M3x8 or M5x10 are supplied with the internal toothed ratchet elements styles A and B.
A stainless steel spring is supplied with the external toothed ratchet elements styles E to H.

Note:

Use DIN 7984 low headed cap screws for fastening the style A and B ratchet elements.

Function:

The ratchet elements are used for rotary adjustment of components. Fastening options can be arranged according to the application.

Drawing reference:

- 1) disengaged
- 2) engaged

Drawings

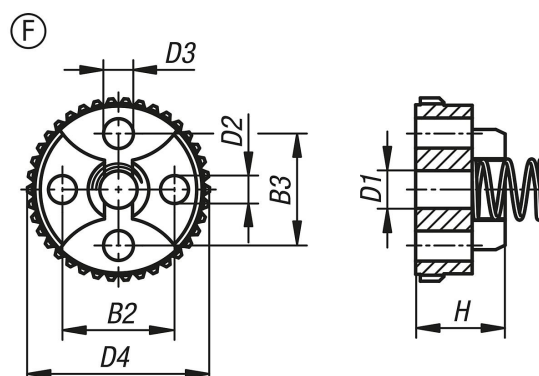

Ratchet elements, style F with external toothing

Order No.	style	Main material	B2	B3	drill Ø D1	D2	D3	D4	H	No. of teeth
K1446.62338	F	steel	12	12	4,2	3H8	3,2	23	9,5	38
K1446.63346	F	steel	18	18	6,2	5H8	5,3	33	13	46
K1446.162338	F	stainless steel	12	12	4,2	3H8	3,2	23	9,5	38
K1446.163346	F	stainless steel	18	18	6,2	5H8	5,3	33	13	46