

Fixed casters

Item description/product images



Description

Material:

Housing stainless steel 1.4301 (AISI 304 equivalent).
Wheels high-quality unbreakable polyamide.

Version:

Housing press styleed.
Double ball bearing in the caster head.
Plain bearing in wheels.

Note:

Wheel axle bolted.
Swivel and fixed casters with mounting plate.
Vibratory ground surface.
Stainless.

Temperature range:

-25 °C to +80 °C.

Drawings

fixed castor

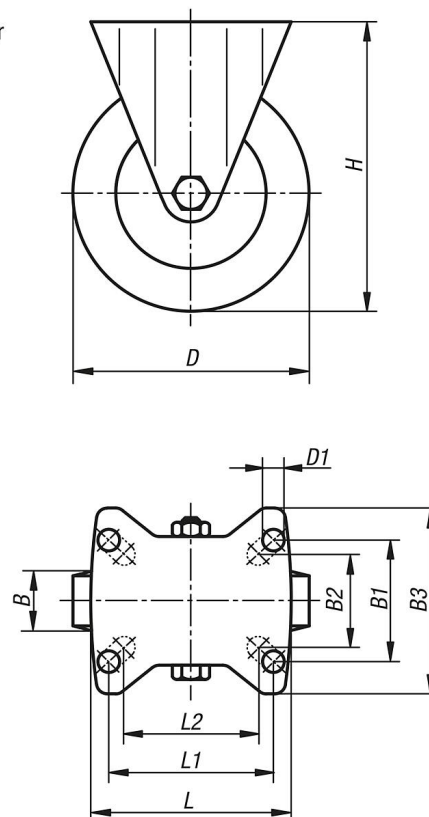

Order No.	Item	Wheel bearing	B	B1	B2	B3	D	D1	H	L	L1	L2	Permissible load kg
K1773.210750321	Fixed caster	plain bearing	32	60	55	85	75	9	100	100	80	76	150
K1773.211000371	Fixed caster	plain bearing	37	60	55	85	100	9	125	100	80	76	150
K1773.211250401	Fixed caster	plain bearing	40	60	55	85	125	9	150	100	80	76	150
K1773.211500501	Fixed caster	plain bearing	50	80	75	110	150	11	190	140	105	-	300