

# Wheels heavy-load wheel body welded

## Item description/product images



### Description

**Material:**

Wheel body welded steel construction.  
Tread Extrathane®.

**Note:**

Extrathane treads are elastic, resist abrasion, gentle to floors, low-noise and have particularly high elastic restoration after long standing.  
Application temperature from -40 °C to +80 °C.  
Suitable as replacement rollers for the casters K1768 and K1769.

## Drawings

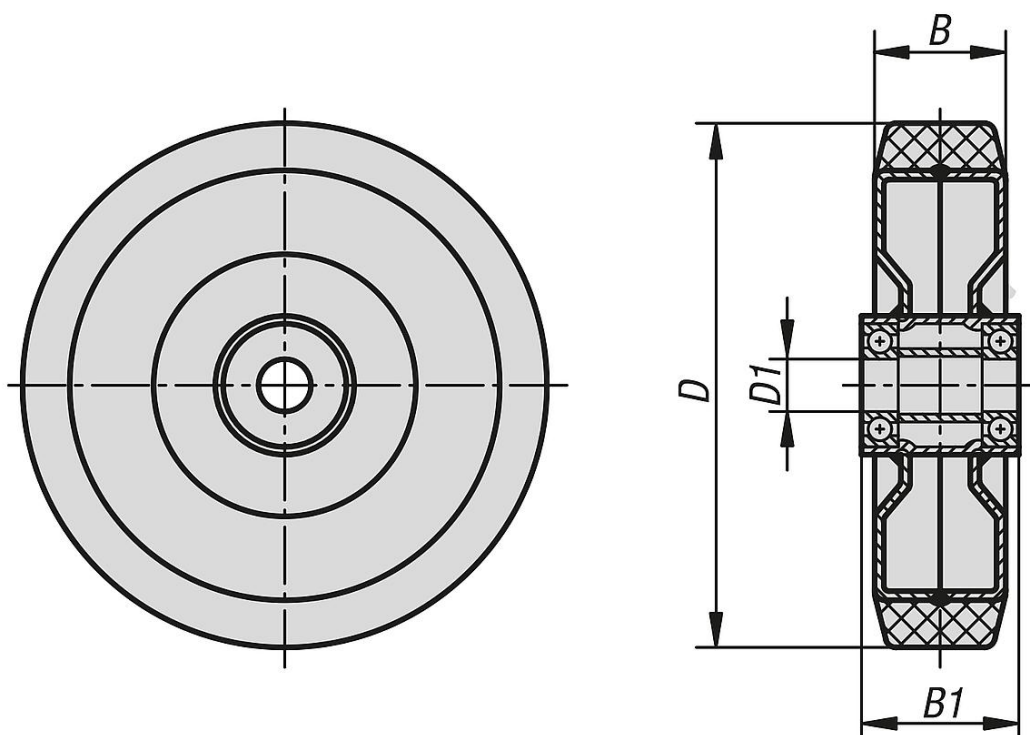

Item No.	Wheel bearing	D	D1	B	B1	Permissible load kg
K1782.12550	ball bearing	125	20	50	60	500
K1782.16050	ball bearing	160	20	50	60	700
K1782.20050	ball bearing	200	20	50	60	1000
K1782.25060	ball bearing	250	25	60	70	1350

