

centering clamp with hexagonal segments, style B

Item description/product images



Description

Material:

Body 1.2842.

Ball and hex segments 1.4112 (AISI 440B equivalent).

Tension spring 1.4310 (AISI 301 equivalent).

Version:

Body hardened and black oxidized.

Ball and hex segments hardened and ground.

Note:

style B: With hexagons for sensitive hole surfaces.

Technical data:

Repetitive accuracy ± 0.025

Concentric accuracy ± 0.05

Application:

For center positioning and clamping in blind holes. Operated from below, manual or automatic using pneumatics or hydraulics.

Benefits:

- Precise self-centering.
- Distortion free clamping.
- Large spread range.
- Low overall height.
- Positive down force.

Drawing reference:

style A:

With balls for holes where light marking is acceptable.

style B:

With hexagons for sensitive hole surfaces.

1) Mounting aid:

pin to accurately position the mandrel segments.

centering clamp with hexagonal segments, style B

Drawings

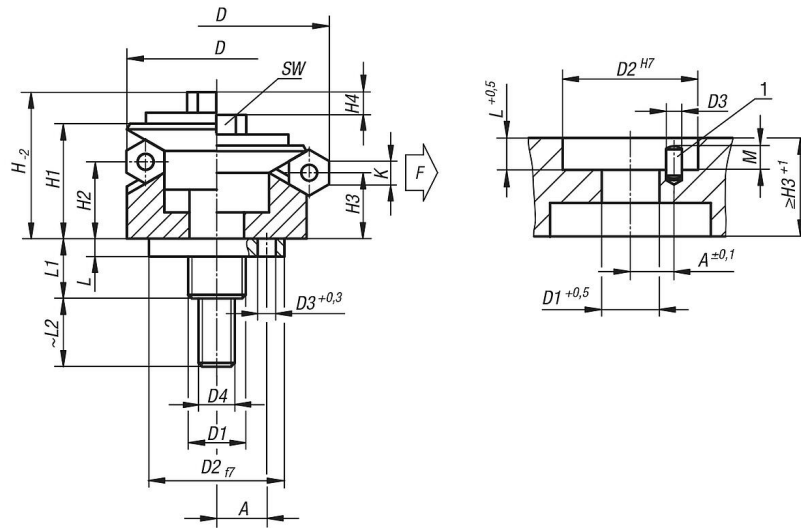

centering clamps with ball or hexagon segments

Order No.	style	A	D min.	D max.	D1	D2	D3	D4	H	H1	H2	H3	H4	L	L1	L2	M	K	SW	No. of hex	Clamping force max. kN	Tightening torque max. Nm
K0644.0201503	B	4,5	14,5	18,5	M6	12	2	M3	17,3	14,5	9,8	8,6	1,4	5,5	14,1	12	2,5	4	5,5	3	3,5	2
K0644.0201904	B	5,5	18,5	22,5	M8	15	2,5	M4	20,9	16,5	11,6	10,4	2,3	7,5	18,2	14	3,5	4	7	3	4	5
K0644.0202305	B	7	22,5	26,5	M10	20	3	M5	25,4	19,8	14,2	13	2,3	6	17,4	15	3,5	4	8	3	4,5	10
K0644.0202705	B	7	26,5	30,5	M10	20	3	M5	25,4	19,8	14,2	13	2,3	6	17,4	15	3,5	4	8	3	4,5	10
K0644.0203106	B	9	30,5	38,5	M12	25	4	M6	30,3	23,1	14,2	11,9	4,6	7	21,9	20	3,5	8	10	6	4,5	17
K0644.0203906	B	11	38,5	46,5	M12	30	4	M6	34,2	27,2	17,8	15,5	4,6	7,5	22,5	20	4,5	8	10	6	6,5	17
K0644.0204706	B	11	46,5	54,5	M12	30	4	M6	34,2	27,2	18	15,7	4,6	7,5	22,5	20	6,5	8	10	6	6,5	17
K0644.0205508	B	15	54,5	70,5	M14	45	5	M8	49,9	40,6	23,7	19,1	9,3	9	24,5	32	6,5	16	13	6	8	43
K0644.0207108	B	17	70,5	86,5	M16	60	5	M8	55,4	46,1	28,3	23,7	9,3	10	29,4	20	6,5	16	13	6	10	43
K0644.0208708	B	25	86,5	102,5	M16	60	5	M10	61,6	51	30,2	25,7	9,3	10	29,4	25	6,5	16	16	6	12,5	79