

Screw-in hydraulic cylinder, single-acting with spring return, style B

Item description/product images



Description

Product description:

The single-acting screw-in cylinders with spring return are characterized by their compact design and are therefore often used as clamping cylinders. They can be positioned very close to each other. Due to the internal stroke limitation, these screw-in cylinders can be operated without an opposing clamping face. The double wipers installed as standard prevent dynamic leakage and thus increase the service life of the screw-in cylinders. The piston is reset to the initial position by means of an integrated spring.

Material:

Housing and piston steel.
Seal NBR

Version:

Housing black oxidized.
Piston hardened.

Note:

The screw-in cylinders can withstand maximum loads in both the tensioned and untensioned state.

To avoid damage to the seals during installation, make sure that the lead-in chamfers as well as the transverse holes for the oil supply are well rounded. A sealing ring at the bottom of the screw-in hole seals the screw-in cylinder. Due to the plunger design, no venting of the rod space is required.

The screw-in cylinders should be protected from aggressive cutting and cooling agents.

Thrust pieces for style B are not supplied.

Follow safety instructions.

Type of operation:

Drilled channels.

Technical data:

Max. operating pressure: 400 bar.

Assembly:

See mounting contour.

Benefits:

- Integrated metal wiper.
- Low mounting dimensions.
- Can be used without opposing clamping face.
- Loads in retracted position possible.
- Lineless pressure supply.

Accessory:

Style B:

- Rest pads K0307.
- Self-aligning pads K0282, K0302, K1164, K0287, K0288.
- Gripper screws, hexagonal K0386.

Screw-in hydraulic cylinder, single-acting with spring return, style B

Item description/product images

Drawing reference:

1) Mounting contour

Drawings

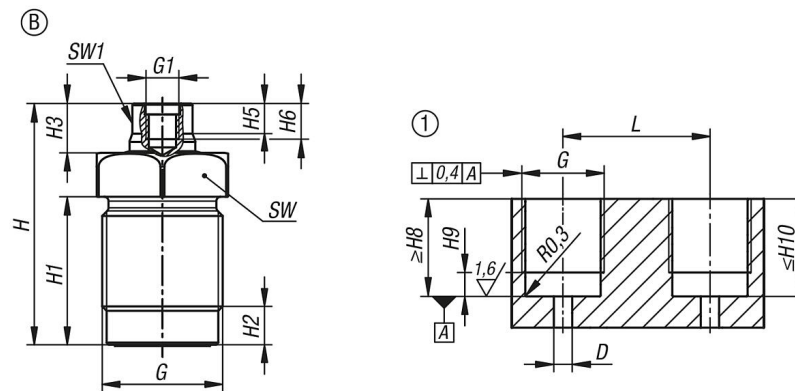

Order No.	style	Piston Ø	travel	Connection type	D	G	G1	H	H1	H2	H3	H5	H6	H8	H9	H10
K1861.1210230811	B	12	10	drilled channels	6	M22x1,5	M6	45	27	7	10	5,5	6,5	15	6	26,5
K1861.1612230811	B	16	12	drilled channels	6	M26x1,5	M6	52,5	34	8	9	5,5	6,5	19	7	33,5
K1861.2015230811	B	20	15	drilled channels	7	M30x1,5	M8	65,5	43	8	13,5	6	8	23	7	42,5
K1861.2516230811	B	25	16	drilled channels	7	M38x1,5	M8	68,5	45,5	11	14	7	8	26,5	10	45
K1861.3220230811	B	32	20	drilled channels	8	M48x1,5	M12	98	71,5	12	18	9	12	40	11	71

Order No.	style	Piston Ø	L	SW1	Clamping force at 100 bar (kN)	Clamping force at 400 bar (kN)	Spring return force min. (N)	Oil requirement / 10mm travel (cm ³)	Tightening torque max. Nm
K1861.1210230811	B	12	31	10	1,1	4,5	30	1,13	40
K1861.1612230811	B	16	34	13	2	8	50	2,01	50
K1861.2015230811	B	20	40	17	3,1	12,5	75	3,14	60
K1861.2516230811	B	25	52	19	4,9	19,6	125	4,91	80
K1861.3220230811	B	32	62	24	8	32	200	8,04	225