

Elastomer dog couplings with clamp hubs, stainless steel

Item description/product images



Description

Material:

Hub stainless steel.

Coupling spider polyurethane.

Version:

Hub bright.

Coupling spider blue Shore 80A.

Coupling spider yellow Shore 92A.

Coupling spider red Shore 98A.

Note:

Elastomer dog coupling consisting of two hubs and an elastomer coupling spider. They are suitable for compensating axial, radial and angular misalignments and for cushioning vibrations and torque shocks.

The polyurethane coupling spiders are available in various hardness grades. As the hardness of the coupling spider increases, the torque and stiffness transmitted increases, and as the hardness decreases, the displacement capacity and cushioning increases.

Pre-tensioning of the spiders in the coupling hubs make this variant play-free.

Supplied unassembled.

Temperature range:

Blue Shore 80A: -50 °C to +80 °C. Briefly -60 °C to +120 °C.

Yellow Shore 92A: -30 °C to +90 °C. Briefly -50 °C to +120 °C.

Red Shore 98A: -30 °C to +90 °C. Briefly -40 °C to +120 °C.

Assembly:

The elastomer dog couplings have an H7 tolerance. The recommended clearance tolerance is 0.02 - 0.05 mm. This tolerance and lubricating the shaft journals aids assembly and removal.

For installation, the hubs of the elastomer dog coupling are simply pushed onto the shafts and secured with clamp hubs.

On request:

Desired hub holes D1 and D2 separately with tolerance class or tolerance zone. DIN 6885 keyway.

Elastomer dog couplings with clamp hubs, stainless steel

Drawings

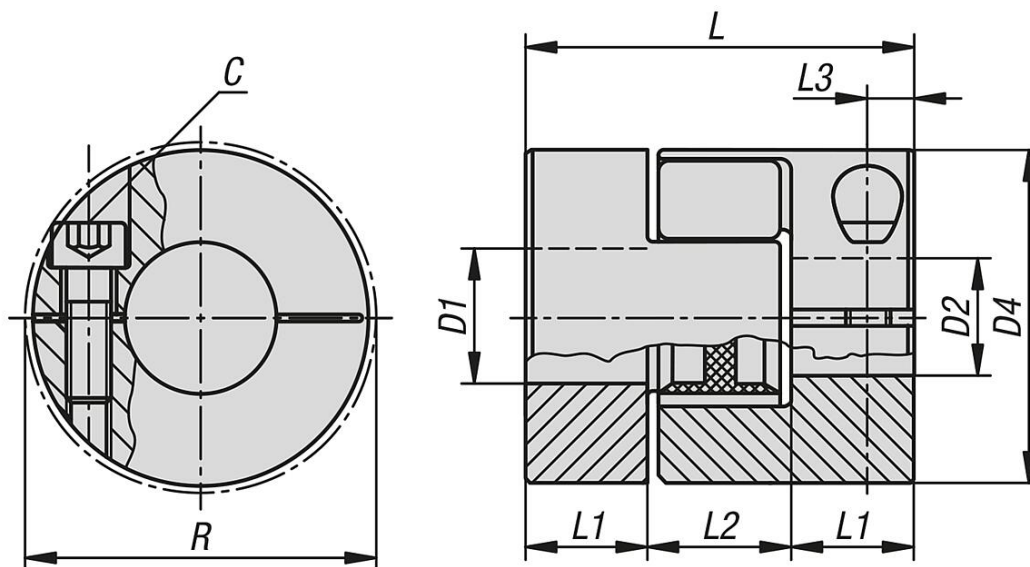

Elastomer dog couplings with clamp hubs, stainless steel

Item No.	Size	Component color	Moment of inertia (gm ²)	Torsional stiffness static (Nm/wheel)	Torsional stiffness dynamic Nm/wheel	Spring stiffness radial (N/mm)	max. shaft offset radial (mm)
K1890.14800350404	14	blue	0,016	60,2	180	153	0,21
K1890.14800350808	14	blue	0,016	60,2	180	153	0,21
K1890.14800350810	14	blue	0,016	60,2	180	153	0,21
K1890.14800350812	14	blue	0,016	60,2	180	153	0,21
K1890.14800350814	14	blue	0,016	60,2	180	153	0,21
K1890.14800351010	14	blue	0,016	60,2	180	153	0,21
K1890.14800351012	14	blue	0,016	60,2	180	153	0,21
K1890.14800351014	14	blue	0,016	60,2	180	153	0,21
K1890.14800351212	14	blue	0,016	60,2	180	153	0,21
K1890.14800351214	14	blue	0,016	60,2	180	153	0,21
K1890.14800351414	14	blue	0,016	60,2	180	153	0,21
K1890.19800661010	19	blue	0,103	618	1065	582	0,15
K1890.19800661212	19	blue	0,103	618	1065	582	0,15
K1890.19800661214	19	blue	0,103	618	1065	582	0,15
K1890.19800661215	19	blue	0,103	618	1065	582	0,15
K1890.19800661216	19	blue	0,103	618	1065	582	0,15
K1890.19800661414	19	blue	0,103	618	1065	582	0,15
K1890.19800661415	19	blue	0,103	618	1065	582	0,15
K1890.19800661416	19	blue	0,103	618	1065	582	0,15
K1890.19800661515	19	blue	0,103	618	1065	582	0,15
K1890.19800661516	19	blue	0,103	618	1065	582	0,15
K1890.19800661616	19	blue	0,103	618	1065	582	0,15
K1890.24800781515	24	blue	0,409	860	1390	840	0,2
K1890.24800781818	24	blue	0,409	860	1390	840	0,2
K1890.24800781819	24	blue	0,409	860	1390	840	0,2
K1890.24800781820	24	blue	0,409	860	1390	840	0,2
K1890.24800781825	24	blue	0,409	860	1390	840	0,2
K1890.24800781919	24	blue	0,409	860	1390	840	0,2
K1890.24800781920	24	blue	0,409	860	1390	840	0,2
K1890.24800781925	24	blue	0,409	860	1390	840	0,2
K1890.24800782020	24	blue	0,409	860	1390	840	0,2
K1890.24800782025	24	blue	0,409	860	1390	840	0,2
K1890.24800782525	24	blue	0,409	860	1390	840	0,2

Elastomer dog couplings with clamp hubs, stainless steel

Item No.	Size	Component color	Moment of inertia (gm ²)	Torsional stiffness static (Nm/wheel)	Torsional stiffness dynamic (Nm/wheel)	Spring stiffness radial (N/mm)	max. shaft offset radial (mm)
K1890.28800901919	28	blue	0,923	1370	2350	990	0,2
K1890.28800902424	28	blue	0,923	1370	2350	990	0,2
K1890.28800902828	28	blue	0,923	1370	2350	990	0,2
K1890.28800903232	28	blue	0,923	1370	2350	990	0,2
K1890.14920350404	14	Yellow	0,016	114,6	344	336	0,15
K1890.14920350808	14	Yellow	0,016	114,6	344	336	0,15
K1890.14920350810	14	Yellow	0,016	114,6	344	336	0,15
K1890.14920350812	14	Yellow	0,016	114,6	344	336	0,15
K1890.14920350814	14	Yellow	0,016	114,6	344	336	0,15
K1890.14920351010	14	Yellow	0,016	114,6	344	336	0,15
K1890.14920351012	14	Yellow	0,016	114,6	344	336	0,15
K1890.14920351014	14	Yellow	0,016	114,6	344	336	0,15
K1890.14920351212	14	Yellow	0,016	114,6	344	336	0,15
K1890.14920351214	14	Yellow	0,016	114,6	344	336	0,15
K1890.14920351414	14	Yellow	0,016	114,6	344	336	0,15
K1890.19920661010	19	Yellow	0,103	1090	1815	1120	0,1
K1890.19920661212	19	Yellow	0,103	1090	1815	1120	0,1
K1890.19920661214	19	Yellow	0,103	1090	1815	1120	0,1
K1890.19920661215	19	Yellow	0,103	1090	1815	1120	0,1
K1890.19920661216	19	Yellow	0,103	1090	1815	1120	0,1
K1890.19920661414	19	Yellow	0,103	1090	1815	1120	0,1
K1890.19920661415	19	Yellow	0,103	1090	1815	1120	0,1
K1890.19920661416	19	Yellow	0,103	1090	1815	1120	0,1
K1890.19920661515	19	Yellow	0,103	1090	1815	1120	0,1
K1890.19920661516	19	Yellow	0,103	1090	1815	1120	0,1
K1890.19920661616	19	Yellow	0,103	1090	1815	1120	0,1
K1890.24920781515	24	Yellow	0,409	2300	5130	1900	0,15
K1890.24920781818	24	Yellow	0,409	2300	5130	1900	0,15
K1890.24920781819	24	Yellow	0,409	2300	5130	1900	0,15
K1890.24920781820	24	Yellow	0,409	2300	5130	1900	0,15
K1890.24920781825	24	Yellow	0,409	2300	5130	1900	0,15
K1890.24920781919	24	Yellow	0,409	2300	5130	1900	0,15
K1890.24920781920	24	Yellow	0,409	2300	5130	1900	0,15
K1890.24920781925	24	Yellow	0,409	2300	5130	1900	0,15
K1890.24920782020	24	Yellow	0,409	2300	5130	1900	0,15
K1890.24920782025	24	Yellow	0,409	2300	5130	1900	0,15
K1890.24920782525	24	Yellow	0,409	2300	5130	1900	0,15
K1890.28920901919	28	Yellow	0,923	4080	6745	1780	0,15
K1890.28920902424	28	Yellow	0,923	4080	6745	1780	0,15
K1890.28920902828	28	Yellow	0,923	4080	6745	1780	0,15
K1890.28920903232	28	Yellow	0,923	4080	6745	1780	0,15
K1890.38921142020	38	Yellow	2,691	6525	12000	2350	0,17
K1890.38921142828	38	Yellow	2,691	6525	12000	2350	0,17
K1890.38921143232	38	Yellow	2,691	6525	12000	2350	0,17
K1890.38921143838	38	Yellow	2,691	6525	12000	2350	0,17
K1890.42921262525	42	Yellow	6,297	10870	20500	4100	0,19
K1890.42921263232	42	Yellow	6,297	10870	20500	4100	0,19
K1890.42921263838	42	Yellow	6,297	10870	20500	4100	0,19
K1890.42921264545	42	Yellow	6,297	10870	20500	4100	0,19
K1890.14980350404	14	red	0,016	171,9	513	654	0,09
K1890.14980350808	14	red	0,016	171,9	513	654	0,09
K1890.14980350810	14	red	0,016	171,9	513	654	0,09
K1890.14980350812	14	red	0,016	171,9	513	654	0,09
K1890.14980350814	14	red	0,016	171,9	513	654	0,09
K1890.14980351010	14	red	0,016	171,9	513	654	0,09
K1890.14980351012	14	red	0,016	171,9	513	654	0,09
K1890.14980351014	14	red	0,016	171,9	513	654	0,09
K1890.14980351212	14	red	0,016	171,9	513	654	0,09
K1890.14980351214	14	red	0,016	171,9	513	654	0,09
K1890.14980351414	14	red	0,016	171,9	513	654	0,09
K1890.19980661010	19	red	0,103	1512	2540	2010	0,06
K1890.19980661212	19	red	0,103	1512	2540	2010	0,06

Elastomer dog couplings with clamp hubs, stainless steel

Item No.	Size	Component color	Moment of inertia (gm ²)	Torsional stiffness static (Nm/wheel)	Torsional stiffness dynamic (Nm/wheel)	Spring stiffness radial (N/mm)	max. shaft offset radial (mm)
K1890.19980661214	19	red	0,103	1512	2540	2010	0,06
K1890.19980661215	19	red	0,103	1512	2540	2010	0,06
K1890.19980661216	19	red	0,103	1512	2540	2010	0,06
K1890.19980661414	19	red	0,103	1512	2540	2010	0,06
K1890.19980661415	19	red	0,103	1512	2540	2010	0,06
K1890.19980661416	19	red	0,103	1512	2540	2010	0,06
K1890.19980661515	19	red	0,103	1512	2540	2010	0,06
K1890.19980661516	19	red	0,103	1512	2540	2010	0,06
K1890.19980661616	19	red	0,103	1512	2540	2010	0,06
K1890.24980781515	24	red	0,409	3700	8130	2940	0,11
K1890.24980781818	24	red	0,409	3700	8130	2940	0,11
K1890.24980781819	24	red	0,409	3700	8130	2940	0,11
K1890.24980781820	24	red	0,409	3700	8130	2940	0,11
K1890.24980781825	24	red	0,409	3700	8130	2940	0,11
K1890.24980781919	24	red	0,409	3700	8130	2940	0,11
K1890.24980781920	24	red	0,409	3700	8130	2940	0,11
K1890.24980781925	24	red	0,409	3700	8130	2940	0,11
K1890.24980782020	24	red	0,409	3700	8130	2940	0,11
K1890.24980782025	24	red	0,409	3700	8130	2940	0,11
K1890.24980782525	24	red	0,409	3700	8130	2940	0,11
K1890.28980901919	28	red	0,923	6410	9920	3200	0,11
K1890.28980902424	28	red	0,923	6410	9920	3200	0,11
K1890.28980902828	28	red	0,923	6410	9920	3200	0,11
K1890.28980903232	28	red	0,923	6410	9920	3200	0,11
K1890.38981142020	38	red	2,691	11800	21850	4400	0,12
K1890.38981142828	38	red	2,691	11800	21850	4400	0,12
K1890.38981143232	38	red	2,691	11800	21850	4400	0,12
K1890.38981143838	38	red	2,691	11800	21850	4400	0,12
K1890.42981262525	42	red	6,297	21594	37692	5940	0,14
K1890.42981263232	42	red	6,297	21594	37692	5940	0,14
K1890.42981263838	42	red	6,297	21594	37692	5940	0,14
K1890.42981264545	42	red	6,297	21594	37692	5940	0,14

Item No.	max. shaft offset axial (mm)	max. angular offset (°)	Max. torque Nm	Coupling spider hardness	Nom. torque Nm
K1890.14800350404	+1 / -0,5	1,1	8	80 Shore A	4
K1890.14800350808	+1 / -0,5	1,1	8	80 Shore A	4
K1890.14800350810	+1 / -0,5	1,1	8	80 Shore A	4
K1890.14800350812	+1 / -0,5	1,1	8	80 Shore A	4
K1890.14800350814	+1 / -0,5	1,1	8	80 Shore A	4
K1890.14800351010	+1 / -0,5	1,1	8	80 Shore A	4
K1890.14800351012	+1 / -0,5	1,1	8	80 Shore A	4
K1890.14800351014	+1 / -0,5	1,1	8	80 Shore A	4
K1890.14800351212	+1 / -0,5	1,1	8	80 Shore A	4
K1890.14800351214	+1 / -0,5	1,1	8	80 Shore A	4
K1890.14800351414	+1 / -0,5	1,1	8	80 Shore A	4
K1890.19800661010	+1,2 / -0,5	1,1	12	80 Shore A	6
K1890.19800661212	+1,2 / -0,5	1,1	12	80 Shore A	6
K1890.19800661214	+1,2 / -0,5	1,1	12	80 Shore A	6
K1890.19800661215	+1,2 / -0,5	1,1	12	80 Shore A	6
K1890.19800661216	+1,2 / -0,5	1,1	12	80 Shore A	6
K1890.19800661414	+1,2 / -0,5	1,1	12	80 Shore A	6
K1890.19800661415	+1,2 / -0,5	1,1	12	80 Shore A	6
K1890.19800661416	+1,2 / -0,5	1,1	12	80 Shore A	6
K1890.19800661515	+1,2 / -0,5	1,1	12	80 Shore A	6
K1890.19800661516	+1,2 / -0,5	1,1	12	80 Shore A	6
K1890.19800661616	+1,2 / -0,5	1,1	12	80 Shore A	6
K1890.24800781515	+1,4 / -0,5	1	34	80 Shore A	17
K1890.24800781818	+1,4 / -0,5	1	34	80 Shore A	17
K1890.24800781819	+1,4 / -0,5	1	34	80 Shore A	17
K1890.24800781820	+1,4 / -0,5	1	34	80 Shore A	17

Elastomer dog couplings with clamp hubs, stainless steel

Item No.	max. shaft offset axial (mm)	max. angular offset (°)	Max. torque Nm	Coupling spider hardness	Nom. torque Nm
K1890.24800781825	+1,4 / -0,5	1	34	80 Shore A	17
K1890.24800781919	+1,4 / -0,5	1	34	80 Shore A	17
K1890.24800781920	+1,4 / -0,5	1	34	80 Shore A	17
K1890.24800781925	+1,4 / -0,5	1	34	80 Shore A	17
K1890.24800782020	+1,4 / -0,5	1	34	80 Shore A	17
K1890.24800782025	+1,4 / -0,5	1	34	80 Shore A	17
K1890.24800782525	+1,4 / -0,5	1	34	80 Shore A	17
K1890.28800901919	+1,5 / -0,7	1,3	92	80 Shore A	46
K1890.28800902424	+1,5 / -0,7	1,3	92	80 Shore A	46
K1890.28800902828	+1,5 / -0,7	1,3	92	80 Shore A	46
K1890.28800903232	+1,5 / -0,7	1,3	92	80 Shore A	46
K1890.14920350404	+1 / -0,5	1	15	92 Shore A	7,5
K1890.14920350808	+1 / -0,5	1	15	92 Shore A	7,5
K1890.14920350810	+1 / -0,5	1	15	92 Shore A	7,5
K1890.14920350812	+1 / -0,5	1	15	92 Shore A	7,5
K1890.14920350814	+1 / -0,5	1	15	92 Shore A	7,5
K1890.14920351010	+1 / -0,5	1	15	92 Shore A	7,5
K1890.14920351012	+1 / -0,5	1	15	92 Shore A	7,5
K1890.14920351014	+1 / -0,5	1	15	92 Shore A	7,5
K1890.14920351212	+1 / -0,5	1	15	92 Shore A	7,5
K1890.14920351214	+1 / -0,5	1	15	92 Shore A	7,5
K1890.14920351414	+1 / -0,5	1	15	92 Shore A	7,5
K1890.19920661010	+1,2 / -0,5	1	24	92 Shore A	12
K1890.19920661212	+1,2 / -0,5	1	24	92 Shore A	12
K1890.19920661214	+1,2 / -0,5	1	24	92 Shore A	12
K1890.19920661215	+1,2 / -0,5	1	24	92 Shore A	12
K1890.19920661216	+1,2 / -0,5	1	24	92 Shore A	12
K1890.19920661414	+1,2 / -0,5	1	24	92 Shore A	12
K1890.19920661415	+1,2 / -0,5	1	24	92 Shore A	12
K1890.19920661416	+1,2 / -0,5	1	24	92 Shore A	12
K1890.19920661515	+1,2 / -0,5	1	24	92 Shore A	12
K1890.19920661516	+1,2 / -0,5	1	24	92 Shore A	12
K1890.19920661616	+1,2 / -0,5	1	24	92 Shore A	12
K1890.24920781515	+1,4 / -0,5	1	70	92 Shore A	35
K1890.24920781818	+1,4 / -0,5	1	70	92 Shore A	35
K1890.24920781819	+1,4 / -0,5	1	70	92 Shore A	35
K1890.24920781820	+1,4 / -0,5	1	70	92 Shore A	35
K1890.24920781825	+1,4 / -0,5	1	70	92 Shore A	35
K1890.24920781919	+1,4 / -0,5	1	70	92 Shore A	35
K1890.24920781920	+1,4 / -0,5	1	70	92 Shore A	35
K1890.24920781925	+1,4 / -0,5	1	70	92 Shore A	35
K1890.24920782020	+1,4 / -0,5	1	70	92 Shore A	35
K1890.24920782025	+1,4 / -0,5	1	70	92 Shore A	35
K1890.24920782525	+1,4 / -0,5	1	70	92 Shore A	35
K1890.28920901919	+1,5 / -0,7	1	190	92 Shore A	95
K1890.28920902424	+1,5 / -0,7	1	190	92 Shore A	95
K1890.28920902828	+1,5 / -0,7	1	190	92 Shore A	95
K1890.28920903232	+1,5 / -0,7	1	190	92 Shore A	95
K1890.38921142020	+1,8 / -0,7	1	380	92 Shore A	190
K1890.38921142828	+1,8 / -0,7	1	380	92 Shore A	190
K1890.38921143232	+1,8 / -0,7	1	380	92 Shore A	190
K1890.38921143838	+1,8 / -0,7	1	380	92 Shore A	190
K1890.42921262525	+2 / -1	1	830	92 Shore A	265
K1890.42921263232	+2 / -1	1	830	92 Shore A	265
K1890.42921263838	+2 / -1	1	830	92 Shore A	265
K1890.42921264545	+2 / -1	1	830	92 Shore A	265
K1890.14980350404	+1 / -0,5	0,9	25	98 Shore A	12,5
K1890.14980350808	+1 / -0,5	0,9	25	98 Shore A	12,5
K1890.14980350810	+1 / -0,5	0,9	25	98 Shore A	12,5
K1890.14980350812	+1 / -0,5	0,9	25	98 Shore A	12,5
K1890.14980350814	+1 / -0,5	0,9	25	98 Shore A	12,5
K1890.14980351010	+1 / -0,5	0,9	25	98 Shore A	12,5

Elastomer dog couplings with clamp hubs, stainless steel

Item No.	max. shaft offset axial (mm)	max. angular offset (°)	Max. torque Nm	Coupling spider hardness	Nom. torque Nm
K1890.14980351012	+1 / -0,5	0,9	25	98 Shore A	12,5
K1890.14980351014	+1 / -0,5	0,9	25	98 Shore A	12,5
K1890.14980351212	+1 / -0,5	0,9	25	98 Shore A	12,5
K1890.14980351214	+1 / -0,5	0,9	25	98 Shore A	12,5
K1890.14980351414	+1 / -0,5	0,9	25	98 Shore A	12,5
K1890.19980661010	+1,2 / -0,5	0,9	42	98 Shore A	21
K1890.19980661212	+1,2 / -0,5	0,9	42	98 Shore A	21
K1890.19980661214	+1,2 / -0,5	0,9	42	98 Shore A	21
K1890.19980661215	+1,2 / -0,5	0,9	42	98 Shore A	21
K1890.19980661216	+1,2 / -0,5	0,9	42	98 Shore A	21
K1890.19980661414	+1,2 / -0,5	0,9	42	98 Shore A	21
K1890.19980661415	+1,2 / -0,5	0,9	42	98 Shore A	21
K1890.19980661416	+1,2 / -0,5	0,9	42	98 Shore A	21
K1890.19980661515	+1,2 / -0,5	0,9	42	98 Shore A	21
K1890.19980661516	+1,2 / -0,5	0,9	42	98 Shore A	21
K1890.19980661616	+1,2 / -0,5	0,9	42	98 Shore A	21
K1890.24980781515	+1,4 / -0,5	0,9	120	98 Shore A	60
K1890.24980781818	+1,4 / -0,5	0,9	120	98 Shore A	60
K1890.24980781819	+1,4 / -0,5	0,9	120	98 Shore A	60
K1890.24980781820	+1,4 / -0,5	0,9	120	98 Shore A	60
K1890.24980781825	+1,4 / -0,5	0,9	120	98 Shore A	60
K1890.24980781919	+1,4 / -0,5	0,9	120	98 Shore A	60
K1890.24980781920	+1,4 / -0,5	0,9	120	98 Shore A	60
K1890.24980781925	+1,4 / -0,5	0,9	120	98 Shore A	60
K1890.24980782020	+1,4 / -0,5	0,9	120	98 Shore A	60
K1890.24980782025	+1,4 / -0,5	0,9	120	98 Shore A	60
K1890.24980782525	+1,4 / -0,5	0,9	120	98 Shore A	60
K1890.28980901919	+1,5 / -0,7	0,9	320	98 Shore A	160
K1890.28980902424	+1,5 / -0,7	0,9	320	98 Shore A	160
K1890.28980902828	+1,5 / -0,7	0,9	320	98 Shore A	160
K1890.28980903232	+1,5 / -0,7	0,9	320	98 Shore A	160
K1890.38981142020	+1,8 / -0,7	0,9	650	98 Shore A	325
K1890.38981142828	+1,8 / -0,7	0,9	650	98 Shore A	325
K1890.38981143232	+1,8 / -0,7	0,9	650	98 Shore A	325
K1890.38981143838	+1,8 / -0,7	0,9	650	98 Shore A	325
K1890.42981262525	+2 / -1	0,9	900	98 Shore A	450
K1890.42981263232	+2 / -1	0,9	900	98 Shore A	450
K1890.42981263838	+2 / -1	0,9	900	98 Shore A	450
K1890.42981264545	+2 / -1	0,9	900	98 Shore A	450

Item No.	max. rpm	C (ISO 4029)	D1 (H7)	D2 (H7)	D1/D2 min.	D1/D2 max.	D4	L	L1	L2	L3	R	Tightening torque of screws Nm
K1890.14800350404	13000	M3	4	4	4	16	30	35	11	13	5	32,2	2
K1890.14800350808	13000	M3	8	8	4	16	30	35	11	13	5	32,2	2
K1890.14800350810	13000	M3	8	10	4	16	30	35	11	13	5	32,2	2
K1890.14800350812	13000	M3	8	12	4	16	30	35	11	13	5	32,2	2
K1890.14800350814	13000	M3	8	14	4	16	30	35	11	13	5	32,2	2
K1890.14800351010	13000	M3	10	10	4	16	30	35	11	13	5	32,2	2
K1890.14800351012	13000	M3	10	12	4	16	30	35	11	13	5	32,2	2
K1890.14800351014	13000	M3	10	14	4	16	30	35	11	13	5	32,2	2
K1890.14800351212	13000	M3	12	12	4	16	30	35	11	13	5	32,2	2
K1890.14800351214	13000	M3	12	14	4	16	30	35	11	13	5	32,2	2
K1890.14800351414	13000	M3	14	14	4	16	30	35	11	13	5	32,2	2
K1890.19800661010	10000	M6	10	10	10	22	40	66	25	16	12	47	15
K1890.19800661212	10000	M6	12	12	10	22	40	66	25	16	12	47	15
K1890.19800661214	10000	M6	12	14	10	22	40	66	25	16	12	47	15
K1890.19800661215	10000	M6	12	15	10	22	40	66	25	16	12	47	15
K1890.19800661216	10000	M6	12	16	10	22	40	66	25	16	12	47	15
K1890.19800661414	10000	M6	14	14	10	22	40	66	25	16	12	47	15
K1890.19800661415	10000	M6	14	15	10	22	40	66	25	16	12	47	15
K1890.19800661416	10000	M6	14	16	10	22	40	66	25	16	12	47	15

Elastomer dog couplings with clamp hubs, stainless steel

Item No.	max. rpm	C (ISO 4029)	D1 (H7)	D2 (H7)	D1/D2 min.	D1/D2 max.	D4	L	L1	L2	L3	R	Tightening torque of screws Nm
K1890.19800661515	10000	M6	15	15	10	22	40	66	25	16	12	47	15
K1890.19800661516	10000	M6	15	16	10	22	40	66	25	16	12	47	15
K1890.19800661616	10000	M6	16	16	10	22	40	66	25	16	12	47	15
K1890.24800781515	7000	M6	15	15	15	32	55	78	30	18	12	56,4	15
K1890.24800781818	7000	M6	18	18	15	32	55	78	30	18	12	56,4	15
K1890.24800781819	7000	M6	18	19	15	32	55	78	30	18	12	56,4	15
K1890.24800781820	7000	M6	18	20	15	32	55	78	30	18	12	56,4	15
K1890.24800781825	7000	M6	18	25	15	32	55	78	30	18	12	56,4	15
K1890.24800781919	7000	M6	19	19	15	32	55	78	30	18	12	56,4	15
K1890.24800781920	7000	M6	19	20	15	32	55	78	30	18	12	56,4	15
K1890.24800781925	7000	M6	19	25	15	32	55	78	30	18	12	56,4	15
K1890.24800782020	7000	M6	20	20	15	32	55	78	30	18	12	56,4	15
K1890.24800782025	7000	M6	20	25	15	32	55	78	30	18	12	56,4	15
K1890.24800782525	7000	M6	25	25	15	32	55	78	30	18	12	56,4	15
K1890.28800901919	6000	M8	19	19	19	37	65	90	35	20	15	72,6	40
K1890.28800902424	6000	M8	24	24	19	37	65	90	35	20	15	72,6	40
K1890.28800902828	6000	M8	28	28	19	37	65	90	35	20	15	72,6	40
K1890.28800903232	6000	M8	32	32	19	37	65	90	35	20	15	72,6	40
K1890.14920350404	13000	M3	4	4	4	16	30	35	11	13	5	32,2	2
K1890.14920350808	13000	M3	8	8	4	16	30	35	11	13	5	32,2	2
K1890.14920350810	13000	M3	8	10	4	16	30	35	11	13	5	32,2	2
K1890.14920350812	13000	M3	8	12	4	16	30	35	11	13	5	32,2	2
K1890.14920350814	13000	M3	8	14	4	16	30	35	11	13	5	32,2	2
K1890.14920351010	13000	M3	10	10	4	16	30	35	11	13	5	32,2	2
K1890.14920351012	13000	M3	10	12	4	16	30	35	11	13	5	32,2	2
K1890.14920351014	13000	M3	10	14	4	16	30	35	11	13	5	32,2	2
K1890.14920351212	13000	M3	12	12	4	16	30	35	11	13	5	32,2	2
K1890.14920351214	13000	M3	12	14	4	16	30	35	11	13	5	32,2	2
K1890.14920351414	13000	M3	14	14	4	16	30	35	11	13	5	32,2	2
K1890.19920661010	10000	M6	10	10	10	22	40	66	25	16	12	47	15
K1890.19920661212	10000	M6	12	12	10	22	40	66	25	16	12	47	15
K1890.19920661214	10000	M6	12	14	10	22	40	66	25	16	12	47	15
K1890.19920661215	10000	M6	12	15	10	22	40	66	25	16	12	47	15
K1890.19920661216	10000	M6	12	16	10	22	40	66	25	16	12	47	15
K1890.19920661414	10000	M6	14	14	10	22	40	66	25	16	12	47	15
K1890.19920661415	10000	M6	14	15	10	22	40	66	25	16	12	47	15
K1890.19920661416	10000	M6	14	16	10	22	40	66	25	16	12	47	15
K1890.19920661515	10000	M6	15	15	10	22	40	66	25	16	12	47	15
K1890.19920661516	10000	M6	15	16	10	22	40	66	25	16	12	47	15
K1890.19920661616	10000	M6	16	16	10	22	40	66	25	16	12	47	15
K1890.24920781515	7000	M6	15	15	15	32	55	78	30	18	12	56,4	15
K1890.24920781818	7000	M6	18	18	15	32	55	78	30	18	12	56,4	15
K1890.24920781819	7000	M6	18	19	15	32	55	78	30	18	12	56,4	15
K1890.24920781820	7000	M6	18	20	15	32	55	78	30	18	12	56,4	15
K1890.24920781825	7000	M6	18	25	15	32	55	78	30	18	12	56,4	15
K1890.24920781919	7000	M6	19	19	15	32	55	78	30	18	12	56,4	15
K1890.24920781920	7000	M6	19	20	15	32	55	78	30	18	12	56,4	15
K1890.24920781925	7000	M6	19	25	15	32	55	78	30	18	12	56,4	15
K1890.24920782020	7000	M6	20	20	15	32	55	78	30	18	12	56,4	15
K1890.24920782025	7000	M6	20	25	15	32	55	78	30	18	12	56,4	15
K1890.24920782525	7000	M6	25	25	15	32	55	78	30	18	12	56,4	15
K1890.28920901919	6000	M8	19	19	19	37	65	90	35	20	15	72,6	40
K1890.28920902424	6000	M8	24	24	19	37	65	90	35	20	15	72,6	40
K1890.28920902828	6000	M8	28	28	19	37	65	90	35	20	15	72,6	40
K1890.28920903232	6000	M8	32	32	19	37	65	90	35	20	15	72,6	40
K1890.38921142020	5000	M8	20	20	20	48	80	114	45	24	20	83,3	40
K1890.38921142828	5000	M8	28	28	20	48	80	114	45	24	20	83,3	40
K1890.38921143232	5000	M8	32	32	20	48	80	114	45	24	20	83,3	40
K1890.38921143838	5000	M8	38	38	20	48	80	114	45	24	20	83,3	40
K1890.42921262525	4000	M10	25	25	25	50	95	126	50	26	20	95	84
K1890.42921263232	4000	M10	32	32	25	50	95	126	50	26	20	95	84
K1890.42921263838	4000	M10	38	38	25	50	95	126	50	26	20	95	84

Elastomer dog couplings with clamp hubs, stainless steel

Item No.	max. rpm	C (ISO 4029)	D1 (H7)	D2 (H7)	D1/D2 min.	D1/D2 max.	D4	L	L1	L2	L3	R	Tightening torque of screws Nm
K1890.42921264545	4000	M10	45	45	25	50	95	126	50	26	20	95	84
K1890.14980350404	13000	M3	4	4	4	16	30	35	11	13	5	32,2	2
K1890.14980350808	13000	M3	8	8	4	16	30	35	11	13	5	32,2	2
K1890.14980350810	13000	M3	8	10	4	16	30	35	11	13	5	32,2	2
K1890.14980350812	13000	M3	8	12	4	16	30	35	11	13	5	32,2	2
K1890.14980350814	13000	M3	8	14	4	16	30	35	11	13	5	32,2	2
K1890.14980351010	13000	M3	10	10	4	16	30	35	11	13	5	32,2	2
K1890.14980351012	13000	M3	10	12	4	16	30	35	11	13	5	32,2	2
K1890.14980351014	13000	M3	10	14	4	16	30	35	11	13	5	32,2	2
K1890.14980351212	13000	M3	12	12	4	16	30	35	11	13	5	32,2	2
K1890.14980351214	13000	M3	12	14	4	16	30	35	11	13	5	32,2	2
K1890.14980351414	13000	M3	14	14	4	16	30	35	11	13	5	32,2	2
K1890.19980661010	10000	M6	10	10	10	22	40	66	25	16	12	47	15
K1890.19980661212	10000	M6	12	12	10	22	40	66	25	16	12	47	15
K1890.19980661214	10000	M6	12	14	10	22	40	66	25	16	12	47	15
K1890.19980661215	10000	M6	12	15	10	22	40	66	25	16	12	47	15
K1890.19980661216	10000	M6	12	16	10	22	40	66	25	16	12	47	15
K1890.19980661414	10000	M6	14	14	10	22	40	66	25	16	12	47	15
K1890.19980661415	10000	M6	14	15	10	22	40	66	25	16	12	47	15
K1890.19980661416	10000	M6	14	16	10	22	40	66	25	16	12	47	15
K1890.19980661515	10000	M6	15	15	10	22	40	66	25	16	12	47	15
K1890.19980661516	10000	M6	15	16	10	22	40	66	25	16	12	47	15
K1890.19980661616	10000	M6	16	16	10	22	40	66	25	16	12	47	15
K1890.24980781515	7000	M6	15	15	15	32	55	78	30	18	12	56,4	15
K1890.24980781818	7000	M6	18	18	15	32	55	78	30	18	12	56,4	15
K1890.24980781819	7000	M6	18	19	15	32	55	78	30	18	12	56,4	15
K1890.24980781820	7000	M6	18	20	15	32	55	78	30	18	12	56,4	15
K1890.24980781825	7000	M6	18	25	15	32	55	78	30	18	12	56,4	15
K1890.24980781919	7000	M6	19	19	15	32	55	78	30	18	12	56,4	15
K1890.24980781920	7000	M6	19	20	15	32	55	78	30	18	12	56,4	15
K1890.24980781925	7000	M6	19	25	15	32	55	78	30	18	12	56,4	15
K1890.24980782020	7000	M6	20	20	15	32	55	78	30	18	12	56,4	15
K1890.24980782025	7000	M6	20	25	15	32	55	78	30	18	12	56,4	15
K1890.24980782525	7000	M6	25	25	15	32	55	78	30	18	12	56,4	15
K1890.28980901919	6000	M8	19	19	19	37	65	90	35	20	15	72,6	40
K1890.28980902424	6000	M8	24	24	19	37	65	90	35	20	15	72,6	40
K1890.28980902828	6000	M8	28	28	19	37	65	90	35	20	15	72,6	40
K1890.28980903232	6000	M8	32	32	19	37	65	90	35	20	15	72,6	40
K1890.38981142020	5000	M8	20	20	20	48	80	114	45	24	20	83,3	40
K1890.38981142828	5000	M8	28	28	20	48	80	114	45	24	20	83,3	40
K1890.38981143232	5000	M8	32	32	20	48	80	114	45	24	20	83,3	40
K1890.38981143838	5000	M8	38	38	20	48	80	114	45	24	20	83,3	40
K1890.42981262525	4000	M10	25	25	25	50	95	126	50	26	20	95	84
K1890.42981263232	4000	M10	32	32	25	50	95	126	50	26	20	95	84
K1890.42981263838	4000	M10	38	38	25	50	95	126	50	26	20	95	84
K1890.42981264545	4000	M10	45	45	25	50	95	126	50	26	20	95	84