

Rod ends with plain bearing, internal thread, narrow head, DIN ISO 12240-1 maintenance-free

Item description/product images



Description

Material:

Housing size (D) 6-10 turned steel.

From size (D) 12 forged steel.

Ball joint ball bearing steel, hardened, ground, polished and hard chromed.

Bearing shell ball bearing steel with PTFE weave glued in.

Version:

Electro zinc-plated.

Note:

The rod end bearing is maintenance-free. The connection dimensions comply with DIN 648 style Series E.

Drawings

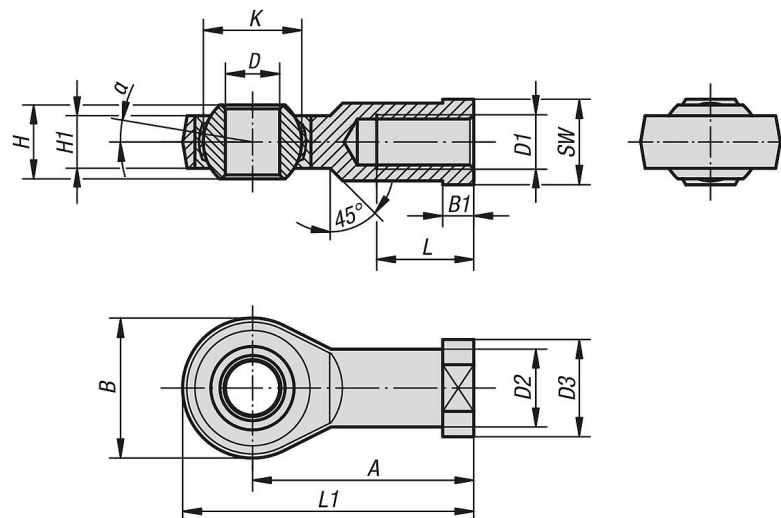

Rod ends with plain bearing, internal thread, narrow head, DIN ISO 12240-1, maintenance-free

Order No.	Version 2	Main material	A	B	B1	D	D1	D2	D3	H	H1	K	L	L1	α	SW	Dynamic base loads kN	Static base loads kN
K2084.06	rh thread	free-cutting steel	30	21	5	6	M6x1,0	10	13	6	4,4	10	11	40,5	13	11	3,6	8,15
K2084.08	rh thread	free-cutting steel	36	24	5	8	M8x1,25	12,5	16	8	6	13	15	48	15	14	5,85	12,9
K2084.10	rh thread	free-cutting steel	43	29	6,5	10	M10x1,5	15	19	9	7	16	20	57,5	12	17	8,65	17,6
K2084.10125	rh thread	free-cutting steel	43	29	6,5	10	M10x1,25	15	19	9	7	16	20	57,5	12	17	8,65	17,6
K2084.12	rh thread	free-cutting steel	50	34	6,5	12	M12x1,75	17,5	22	10	8	18	23	67	11	19	11,4	24,5
K2084.12125	rh thread	free-cutting steel	50	34	6,5	12	M12x1,25	17,5	22	10	8	18	23	67	11	19	11,4	24,5
K2084.17	rh thread	carbon steel	67	46	10	17	M16x2,0	24	30	14	14	25	34	90	10	27	22,4	45
K2084.20	rh thread	carbon steel	77	53	10	20	M20x1,5	27,5	35	16	16	29	40	103,5	9	32	31,5	60
K2084.25	rh thread	carbon steel	94	64	12	25	M24x2,0	33,5	42	20	20	35,5	48	126	7	36	51	83
K2084.30	rh thread	carbon steel	110	73	15	30	M30x2,0	40	50	22	22	40,7	56	146,5	6	41	66,5	110
K2084.061	lh thread	free-cutting steel	30	21	5	6	M6x1,0	10	13	6	4,4	10	11	40,5	13	11	3,6	8,15
K2084.081	lh thread	free-cutting steel	36	24	5	8	M8x1,25	12,5	16	8	6	13	15	48	15	14	5,85	12,9
K2084.101	lh thread	free-cutting steel	43	29	6,5	10	M10x1,5	15	19	9	7	16	20	57,5	12	17	8,65	17,6
K2084.101251	lh thread	free-cutting steel	43	29	6,5	10	M10x1,25	15	19	9	7	16	20	57,5	12	17	8,65	17,6
K2084.121	lh thread	free-cutting steel	50	34	6,5	12	M12x1,75	17,5	22	10	8	18	23	67	11	19	11,4	24,5
K2084.121251	lh thread	free-cutting steel	50	34	6,5	12	M12x1,25	17,5	22	10	8	18	23	67	11	19	11,4	24,5

Rod ends with plain bearing, internal thread, narrow head, DIN ISO 12240-1 maintenance-free

Order No.	Version 2	Main material	A	B	B1	D	D1	D2	D3	H	H1	K	L	L1	α	SW	Dynamic base loads kN	Static base loads kN
K2084.171	lh thread	carbon steel	67	46	10	17	M16x2,0	24	30	14	14	25	34	90	10	27	22,4	45
K2084.201	lh thread	carbon steel	77	53	10	20	M20x1,5	27,5	35	16	16	29	40	103,5	9	32	31,5	60
K2084.251	lh thread	carbon steel	94	64	12	25	M24x2,0	33,5	42	20	20	35,5	48	126	7	36	51	83
K2084.301	lh thread	carbon steel	110	73	15	30	M30x2,0	40	50	22	22	40,7	56	146,5	6	41	66,5	110