

Spring plungers with hex socket and thrust pin, standard spring force, with thread lock - inch

Item description/product images

INCH KIPlock
Parts



Description

Material:

Sleeve in steel grade 5.8;
thrust pin in steel.
Spring grade D spring steel wire.

Thread lock nylon.

Version:

Black oxidized.
Thrust pin hardened.

Note:

For the inch series, dimension D and S are in inches, all other dimensions are in mm.

Drawing reference:

L2 = ca. two full threads

1) grub screw glued-in

Drawings

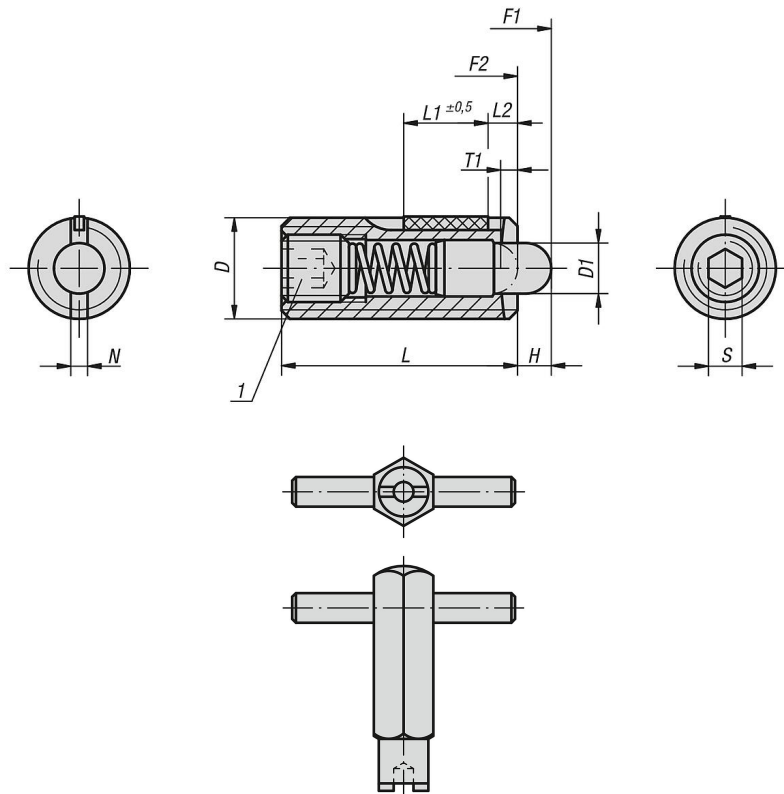

Item No.	D	D1	H	L	L1	T1	N	S	Spring force initial pressure F1 approx. N	Spring force final pressure F2 approx. N	Tightening torque approx. Nm	Loosening torque approx. Nm	Item No. Installation tool
K0327.A2	1/4-20	2,7	2,5	20	7	1	1	2	7	20	0,45	0,22	K0317.906
K0327.A6	5/8-11	7,5	5	32	14	2,5	2,5	5	45	100	3,9	3	K0317.916

Spring plungers with hex socket and thrust pin, standard spring force, with thread lock - inch

Item No.	D	D1	H	L	L1	T1	N	S	Spring force initial pressure F1 approx. N	Spring force final pressure F2 approx. N	Tightening torque approx. Nm	Loosening torque approx. Nm	Item No. Installation tool
K0327.A1	10-32	2,4	2,3	18	7	0,8	0,8	1,5	6	20	0,12	0,08	K0317.905
K0327.AJ	1/4-28	2,7	2,5	20	7	1	1	2	7	20	0,45	0,22	K0317.906
K0327.A5	1/2-13	6	4	28	10	2	2	4	12	55	2	1,3	K0317.912
K0327.A3	5/16-18	3,5	3	22	8	1,4	1,2	2,5	9	35	1,05	0,37	K0317.908
K0327.A4	3/8-16	4	3	22	9	1,4	1,6	3	9	35	1,3	0,6	K0317.910